

JP·EnErG Pro

LIPRO QUAD 6



Instruction Manual

Contents

Introduction	1
Specifications	1
Box Contents	1
Controls	2
Power supply	2
Special features	3
Optimized operating software	3
Internal independent lithium battery balancer	3
Balancing individual cells battery discharging	3
Adaptable to various types of lithium battery	3
Fast and storage mode of lithium battery	3
Maximum safety.....	3
Automatic charging current limit	3
Capacity limit	3
Processing time limit.....	3
Data store/load.....	4
Cyclic charging/discharging.....	4
Temperature threshold*	4
PC based analysis using USB Communication**.....	4
Warning and safety notes	5
Charging	6
Discharging.....	6
Operating parameters	7
Main menu	8
Selecting a Program.....	8
Power supply and final safety checks	9
Power Supply	9
Final checks before connecting the battery	9
User set program option	10
Safe timer Calculation.....	11
Charge & Discharge Programs	12
Lithium charge program	12
Lithium Balance charge program	14
Viewing the Voltage of Individual Cells.....	14
Lithium fast charging.....	15
Lithium Storage charging	16
Lithium Discharging Program	17
NiMH and NiCd Charge programs	18
NiMH and NiCd Discharge programs.....	19
NiMH and NiCd Cycle Charge programs	20
Gel cell (pb, lead acid) charge program	21
Gel cell (pb, lead acid) discharge program	22
Save Data Program	23
Load Data Program	24
Viewing Extra Charge/Discharge Data	24
Viewing the "User Set Program" Settings	24
Monitoring the Voltage of Individual Cells	24
Warnings and Error Messages	25

WARRANTY

J. Perkins Distribution Ltd. guarantee this product to be free of manufacturing or assembly defects for a period of one year from time of purchase. This does not affect your statutory rights. This warranty is not valid for any damage or subsequent damage arising as a result of a misuse, modification or for damage or consequential damage arising as a result of failure to observe the procedures outlined in this manual. Operation of this product is carried out entirely at the risk of the operator. Please note that, whilst every effort is made to ensure the accuracy of instructions and material included with this product, mistakes can occur and neither J. Perkins Distribution Ltd nor it's distributors will be held liable for any loss or damage arising from the use of this product or for any loss or damage arising from omissions or inaccuracies in the associated instructions or materials included with this product.

We reserve the right to modify the design of this product, contents and manuals without prior notification.

© 2009 J Perkins Distribution Ltd, Lenham, Kent, UK ME17 2DL.
www.jperkinsdistribution.co.uk

EU REGULATIONS

J Perkins Distribution Ltd declares that this product is in compliance with the essential requirements and other relevant provisions of Directive 2204/108 EC on Electromagnetic Compatibility. A copy of the declaration(s) of conformity can be obtained from J Perkins Distribution Ltd, Ashford rd, Lenham, Kent. UK ME17 2DL. This system complies with the EU directive on Waste Electrical and Electronic Equipment. Do not dispose of this product in household waste. At the end of the products' life, dispose of it at a designated collection point for the recycling of waste electrical and electronic equipment.

Please contact your supplier for any advice required on disposal.



INTRODUCTION

Thank you for purchasing the JP EnErG LiPro Quad 6 balancer charger. This product is a compact charger with battery management and integral balancer. The unit is simple to use, but the operation of a sophisticated automatic charger such as the LiPro Quad 6 does require some knowledge on the part of the user. These operating instructions are designed to ensure that you quickly become familiar with its functions. It is therefore important that you read right through the Instruction manual and Warning and Safety Notes before you attempt to use your new automatic charger for the first time.

The LiPro Quad 6 employs the circuit that features four totally independent but identical power outputs which are powered 50 watts each. Total power is 200 watts. As a result, it can charge or discharge up to 4 x 15 cells of NiCd/NiMH or 4 x 6 series of Lithium batteries simultaneously. LiPro Quad 6 has four individual cell voltage balancers at each output, so it does not require a separate balancer when charging Lithium batteries (LiPo/LiIon/LiFe) for voltage balancing.

The twin-fan cooling system is so smart and efficient. The fan speed is controlled by internal temperature sensor.

The following instructions apply to one of the four chargers, as all of them operate according to same principle. Please BE SURE to read these instructions and Warning and Safety Notes before you use the charger for the first time.

It can be dangerous to mishandle batteries and battery chargers, as there is always a risk of batteries catching fire and exploding.

SPECIFICATIONS

Operating voltage range:	11.0-15.0V
Circuit power:	max. 50W (current is regulated accordingly)
Charge current range:	0.1 - 5.0A
Current drain for balancing Lithium:	300mAh/cell
NiCd/NiMH battery cell count:	1-15 cells
Lithium battery cell count:	1-6 cells
Gel cell battery voltage:	2-20V
Weight:	1.09Kg
Dimensions:	226 x 159 x 63 mm

BOX CONTENTS



1. LiPro Quad 6
2. Large crocodile clips
3. TP/FP balance board adapter
4. XH balance board adapter
5. Crocodile clip charging cable
6. Tamiya style charging cable
7. Futaba style charging cable
8. JST/BEC charging cable
9. 18AWG wire charging cable

CONTROLS

LCD Screen



Menu control buttons

Battery sockets

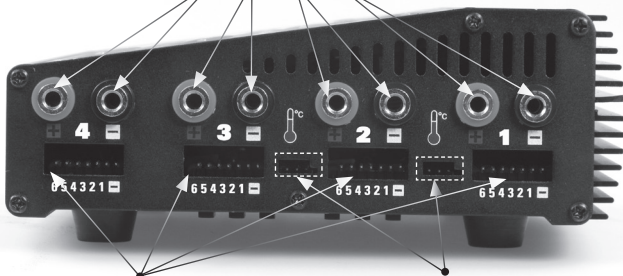

Universal balancing port

Temp sensor/PC link
Available for Charger 1 and 2 only

INPUT 11-15V

Twin ventilation fan
with temperature sensor control

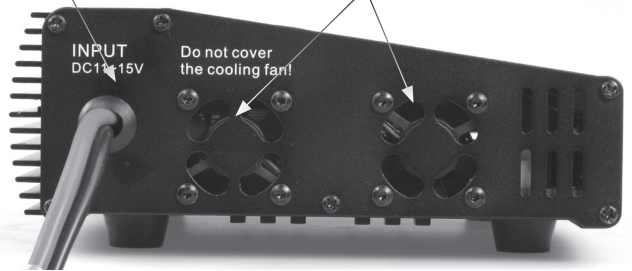

POWER SUPPLY



The LiPro Quad 6 comes with 4mm connectors and crocodile clips for direct 11-15V DC battery connection.

SPECIAL FEATURES

LiPro Quad 6 allows you to plug 4 batteries into one charger simultaneously, and it will intelligently and automatically charge all 4 of them at once to their maximum capacity. To top it off, the batteries being charged do not even need to have the same configuration. You can connect different chemistry Ni-MH/Ni-CD/LiPo/LiFe batteries into any of the charging ports. No more staying up late for charging batteries!

OPTIMIZED OPERATING SOFTWARE

LiPro Quad 6 features an AUTO function that sets the feeding current during the process of charging or discharging. Especially for Lithium batteries, it can prevent overcharging which may lead to an explosion due to the user's fault. It can disconnect the circuit automatically and alert the user once a malfunction is detected. All the programs of this product are controlled through two way linkage and communication, to achieve the maximum safety and minimize the trouble. All the settings can be configured by users!

INTERNAL INDEPENDENT LITHIUM BATTERY BALANCER

LiPro Quad 6 features an individual-cell-voltage balancer. It isn't necessary to connect an external balancer for balance charging.

BALANCING INDIVIDUAL CELLS BATTERY DISCHARGING

During the process of discharging, the LiPro Quad 6 can monitor and balance each cell of the battery individually. An error message will be shown and the process will be ended automatically if the voltage of any single cell is abnormal.

ADAPTABLE TO VARIOUS TYPES OF LITHIUM BATTERY

LiPro Quad 6 is adaptable to various types of Lithium batteries, such as Li-ion, LiPo and the new LiFe series of batteries.

FAST AND STORAGE MODE OF LITHIUM BATTERY

Lithium battery charge purposes can vary, so you have the option to choose between fast charge and store charge method. 'fast' charge reduces the duration of charging, whereas 'store' state can control the final voltage of your battery, so it can be stored for a period of time and protect the lifespan of the battery.

MAXIMUM SAFETY

Delta-peak sensitivity: The automatic charge termination program based on the principle of the Delta-peak voltage detection. When the battery's voltage exceeds the threshold, the process will be terminated automatically.

AUTOMATIC CHARGING CURRENT LIMIT

You can set up the upper limit of the charging current when charging your NiCd or NiMH battery; it is useful for the NiMH battery of low impedance and capacity in the 'AUTO' charging mode.

CAPACITY LIMIT

The charging capacity is always calculated as the charging current multiplied by time. If the charging capacity exceeds the limit, the process will be terminated automatically when you set the maximum value.

PROCESSING TIME LIMIT

You can also limit the maximum process time to avoid any possible defect.

DATA STORE/LOAD

Five batteries' data can be stored per charger (20 in total on the LiPro Quad 6). This means you can store settings for particular batteries charge and discharge often. This data can be loaded at any time to avoid the need to set program settings every time.

CYCLIC CHARGING/DISCHARGING

1 to 5 cyclic and continuous process of charge>discharge or discharge>charge is operable for battery refreshing and balancing to stimulate the battery's activity.

TEMPERATURE THRESHOLD*

The battery's internal chemical reaction will cause the temperature of the battery to rise. If the temperature limit is reached, the process will be terminated.

* This function is available by connecting optional temperature probe, which is not included in the package.

PC BASED ANALYSIS USING USB COMMUNICATION**

LiPro Quad 6 PC based program can analysis the characteristic of the battery via USB port. It shows a graph of voltage, current, capacity curves. It also shows the individual voltage of each cell in the Lithium battery pack.

**This function is available by connecting optional PC-LINK USB adaptor, which is not included in the package.

WARNING AND SAFETY NOTES

These warnings and safety notes are particularly important. Please follow the instructions for maximum safety; otherwise the charger and the battery can be damaged or at worst it can cause a fire.

- Never leave the charger unsupervised when it is connected to a power supply. If any malfunction is observed immediately terminate the process and refer to the operation manual.
- Keep the unit away from dust, damp, rain, heat, direct sunshine and vibration. Do not drop it.
- The circuit of the unit is designed to be powered by an 11-15V power source.
- This unit and the battery to charge or discharge should be set up on a heat-resistant, noninflammable and non-conductive surface. Never place them on a car seat, carpet or similar surface.
- Never use this charger inside a car, van or any other motor vehicle.
- Do not cover or close the cooling vent.
- Keep all inflammable volatile materials well away from the chargers operating area.
- Never charge batteries fitted inside models, always remove them before charging.
- Make sure you know the specifications of the battery to be charged or discharged to ensure it meets the requirements of this charger. If the program is set up incorrectly the battery and charger may be damaged.
- To avoid short-circuits between the charge lead always connect the charge cable to the charger first, then connect the battery. Reverse the sequence when disconnecting.
- Do not connect more than one battery pack to this charger at any one time.
- Do not attempt to charge or discharge the following types of battery.
 - A battery pack which consists of different types of cell (including different manufacturers)
 - A battery that is already fully charged or just slightly discharged.
 - Non-rechargeable batteries (Explosion hazard).
 - Batteries that require a different charge technique from NiCd, NiMH, Lilo, Li-Poly, LiFe or Gel cell (Pb, Lead acid).
 - A faulty or damaged battery.
 - A battery fitted with an integral charge circuit or a protection circuit.
 - Batteries installed in a device or which are electrically linked to other components.
 - Batteries that are not expressly stated by the manufacturer to be suitable for the currents the charger delivers during the charge process.

CHARGING

A specific quantity of electrical energy is fed into the battery during the charge process. The charge quantity is calculated by multiplying charge current by charge time. The maximum permissible charge current varies according to the battery type and performance and can be found in the information supplied by the battery manufacturer. Only charge batteries at a higher rate than the standard charge rate if the battery is specifically stated to be capable of quick charge.

Only connect the battery to the output terminal of the charger using a suitable charge lead. They are red, positive (+) and black, negative (-). Since the charger cannot detect the difference between the internal resistances of the battery pack, cable resistance and connector transfer resistance, the first requirement if the charger is to work properly, is that the charge lead should be made of adequate conductor cross-section. The charge lead must also have high-quality connectors at both ends (gold connector type).

Refer to the information provided by the battery manufacturer regarding charging methods and verify the recommended charge current and charge time. Lithium battery packs require the specifications to be followed strictly.

Do not attempt to disassemble the battery pack.

Lithium battery packs can be wired in parallel or series circuits. Make sure you know which way your battery pack is wired and be aware of it's capacity. In a parallel circuit the capacity of the pack is multiplied by the number of cells but the voltage stays the same. This kind of voltage imbalance can cause fire or explosion during the charge process, therefore we recommend you only use Lithium battery packs in series only.

DISCHARGING

The typical purpose of discharge is to determine the residual capacity of the battery or to lower the voltage to a defined level. When you discharge a battery as much attention should be applied to the process as if you were charging the battery. To avoid the battery becoming over discharged set the final discharge voltage correctly. Lithium batteries should not be over discharged lower than the minimum voltage as this leads to rapid loss of capacity or total failure. Generally you do not need to discharge lithium battery packs voluntarily.

NiCd and NiMH rechargeable batteries are said to have a "memory effect". If they are partially used and recharged before the whole charge is drawn out, they "remember" this and next time will only use that part of their capacity. For this reason they prefer complete cycles, fully charge then use until they are empty.

Lithium batteries prefer a partial recharge, frequent discharges should be avoided if possible, instead charge the battery more often.

Brand new NiCd packs do not perform to full capacity until they have been subjected to 10 or more charge cycles. The cyclic process of charge-discharge will be useful in this case.

OPERATING PARAMETERS

NiCd/NiMH

Voltage level:	1.2V/cell
Allowable fast charge current:	1-2C (depending on the performance of the cell)
Discharge voltage cut off level:	NiCd: 0.85V/cell NiMH: 1.0V/cell

Lilo

Voltage level:	3.6V/cell
Max charge voltage:	4.1V
Allowable fast charge current:	1C or less
Min. discharge voltage cut off level:	2.5V/cell or higher

LiPo

Voltage level:	3.7V/cell
Max charge voltage:	4.2V
Allowable fast charge current:	1C or less
Discharge voltage cut off level:	3.0V/cell or higher

LiFe

Voltage level:	3.3V/cell
Max charge voltage:	3.6V
Allowable fast charge current:	4C or less
Discharge voltage cut off level:	2.0V/cell or higher

Gel Cell (Pb, Lead Acid)

Voltage level:	2V/cell
Max charge voltage:	2.46V
Allowable fast charge current:	0.4C or less
Discharge voltage cut off level:	1.75V/cell or higher

NOTE: This charger has a maximum output of 50 watts. You can determine the maximum available current (A) by dividing 50 (W) by the battery pack voltage (V). $W/V = A$.

The maximum safe charge current that can be set is determined by the type of cells and the manufacturers recommendation. This is often 1C (1 x capacity of cells) for LiPo and NiMH batteries.

MAIN MENU

Please bear in mind the following points before commencing charging:

- Did you select the appropriate program suitable for the type of battery you will be charging?
- Did you set up correct current for charging or discharging?
- Have you checked the type of battery you are charging, i.e. LiPo, NiMH, NiCd, Gel?
- Have you checked the battery voltage? Lithium battery packs can be wired in parallel and in series, i.e. a 2 cell pack can be 3.7V (in parallel) or 7.4V (in series).
- Have you checked that all connections are firm and safe? Make sure there are no intermittent contacts at any point in the circuit.

SELECTING A PROGRAM

By pressing the "Batt Type/Stop" button repeatedly the main menu will scroll through the different charge program options and the user settings option.

To select an option from the main menu press the "Start/Enter" button.

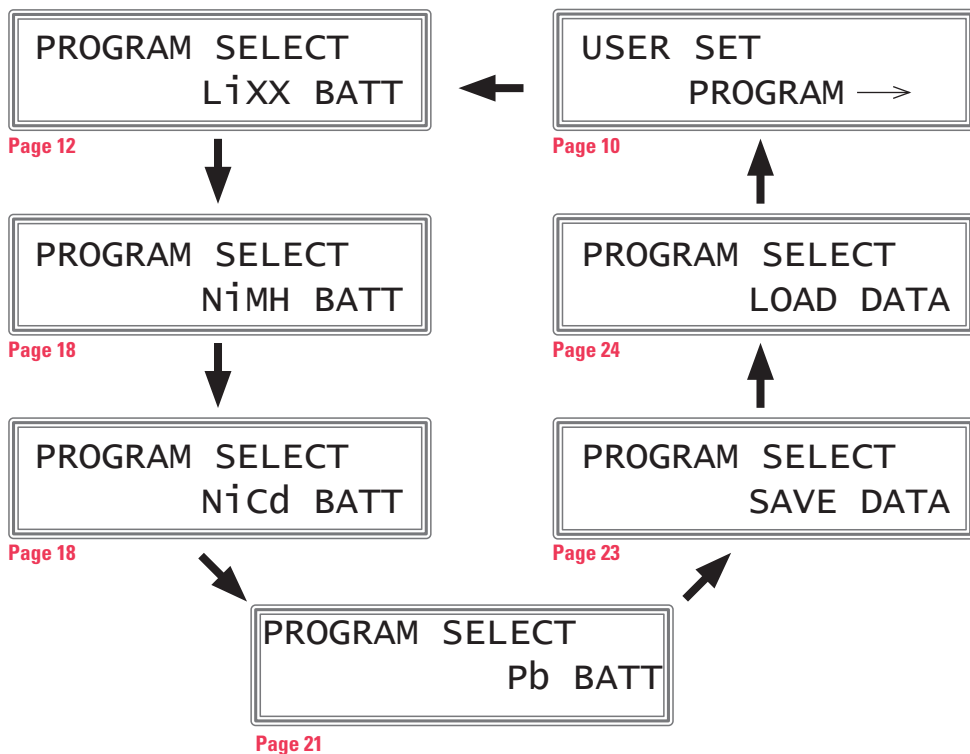

POWER SUPPLY AND FINAL SAFETY CHECKS

POWER SUPPLY

LiPro Quad 6 comes with male 4mm Bullet connectors attached to the power INPUT cables. These cables are appropriate for attaching directly to most high quality AC-DC power supply units. Also included are large crocodile clips with matching 4mm female bullet connectors, for attaching directly to 12V DC batteries. It is important that you use a high quality AC-DC power supply in the range of 12V to 15V DC output, with minimum current rating of 20A to insure reliable performance.

FINAL CHECKS BEFORE CONNECTING THE BATTERY

Important! Before connecting a battery it is absolutely essential to check one last time that you have set the parameters correctly. If the settings are incorrect, the battery may be damaged, and could even burst into flames or explode. To avoid short -circuits between the banana plugs, always connect the charge leads to the charger first, and only then to the battery. Reverse the sequence when disconnecting the pack.

Balance socket:

The balance wire attached to the battery must be connected to the charger with the black wire aligned with the negative marking. Take care to maintain correct polarity! (Wiring diagram: see below.)

This diagram shows the correct way to connect your battery to the LiPro Quad 6 while charging in the balance charge program mode only:

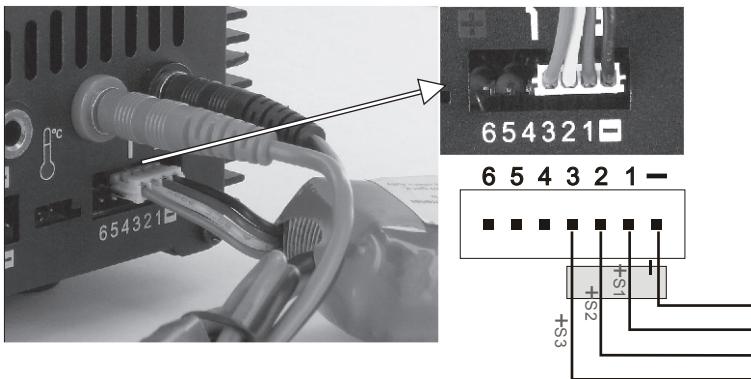

Warning!

Failure to connect as shown in this diagram will damage this charger!

USER SET PROGRAM OPTION

As default, this charger will be set to typical user settings when it is connected to a 12V battery for the first time. This settings menu can be accessed by selecting **User Set Program** from the main menu by pressing the "Start/Enter" button.

Scroll through the different options in the User Set Program menu by pressing the "INC" or "DEC" buttons.

If you need to alter the settings for an option press the "Start/Enter" button to make it blink then change the value with "DEC" or "INC" button. The value will be stored by pressing "Start/Enter" button.

To exit from the **User Set Program** menu press the "Batt type/Stop" button.

Select USER SET PROGRAM from the main menu by pressing the "Start/Enter" button



Start
Enter

This screen displays the nominal voltage of the Lithium battery. There are 3 kinds of Lithium battery: LiPo (3.7V) LiIo (3.6V) or LiFe (3.3V). It is very important that you choose the correct battery type in this menu before trying to charge it. Using the wrong setting could cause the battery to explode during the charge process.

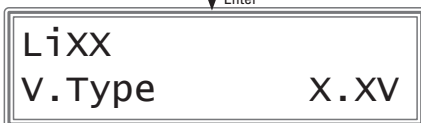

INC
DEC

The safety timer automatically begins running when the charge process starts. This function is to prevent over charge of the battery if it proves to be faulty, or if the termination circuit does not detect a peak. The timer limit should not be set lower than the time needed to allow a full charge of the battery.

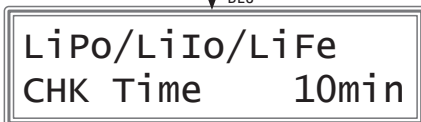

INC
DEC

These settings show the trigger voltage for automatic charge termination of NiMH and NiCd batteries. The values can be set between 5-20mV/cell. If the trigger voltage is set too high there is a danger of over charging the battery; if it is set lower, there is a possibility of premature termination. Please refer to the technical specification of the battery supplied by the manufacturer.

Default settings: NiCd - 12mV/cell
NiMH: - 7mV/cell

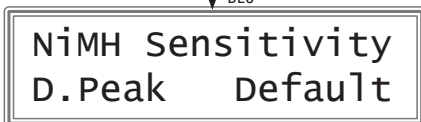

INC
DEC



INC
DEC

An optional feature using a temperature probe (not supplied) contacting the surface of battery. The temperature cut-off can be on or off. If it is on, set the maximum temperature at which the charger should allow battery to reach during charge. Once a battery reaches this temperature during charge, the process will be terminated to protect the battery.

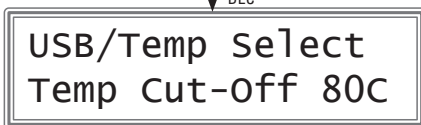

INC
DEC

SAFE TIMER CALCULATION

When charging NiCd or NiMH batteries, divide the capacity by current, then divide the result by 11.9, set this number of minutes as the value for safety timer setting. If the charger stopped at this time threshold, about 140% of the capacity will have been fed into the battery.

For example:

Capacity Current Safety Time

2000mAh 2.0A (2000/2.0=1000)/11.9=84 minutes

3300mAh 3.0A (3300/3.0=1100)/11.9=92 minutes

1000mAh 1.2A (1000/1.2=833)/11.9=70 minutes

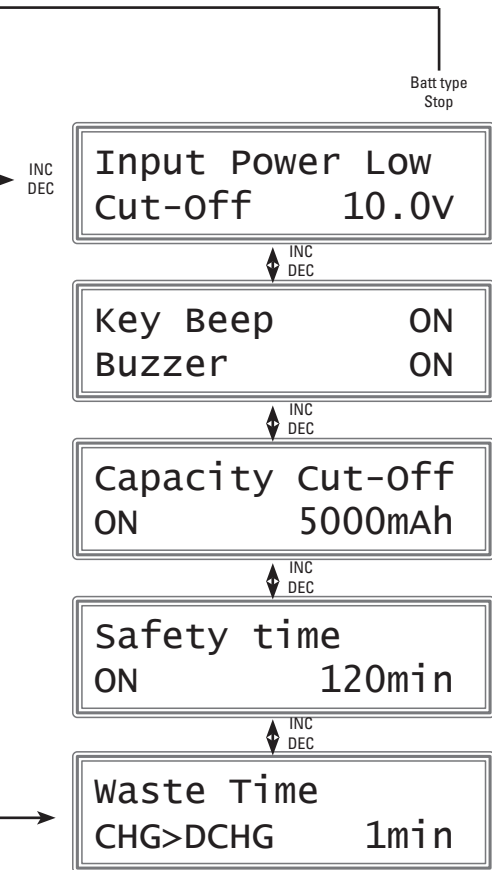

This function monitors the voltage of the input battery used to power this charger. If the voltage of the input drops below the value you have set the charge process will be terminated to protect the input battery.

If the KEY BEEP function is switched ON a beep will sound every time a button is pressed to confirm your action.

If the BUZZER function is switched ON a beep or melody will sound to alert you of changes in the charge process, including errors.

These functions can be switched ON or OFF independently.

This program sets the maximum charge capacity that will be supplied to the battery during charge. If the delta-peak voltage is not detected nor the safety timer expired, then this feature will automatically stop the charge process at the selected capacity value.

The safety timer automatically begins running when the charge process starts. This function is to prevent over charge of the battery if it proves to be faulty, or if the termination circuit does not detect a peak. The timer limit should not be set lower than the time needed to allow a full charge of the battery. Please refer to the above "Safe timer calculation" to calculate the timer you set.

When using the cyclic charge process the battery can often become quite warm after a charge or discharge period. This setting allows you to program in a time delay between charge and discharge programs. This gives the battery time to cool down before subjecting it to the next process. The value ranges from 1-60minutes.

CHARGE & DISCHARGE PROGRAMS

Please ensure you choose the correct process for the type of battery you will be charging or discharging as each type of battery uses a different charge and discharge techniques. These techniques are built into the different programs set up on the LiPro Quad 6.

LITHIUM CHARGE PROGRAM

- The following program is only suitable for charging Lithium batteries with a nominal voltage of 3.3V, 3.6V and 3.7V per cell. Do not try to charge any other type of battery using this program.

The charge current varies according to the battery capacity and performance. The final voltage of charge process is also very important; it should be 4.2V/cell for LiPo, 4.1V/cell for Lilo and 3.6V/cell for LiFe. If the final voltage exceeds these values by more than 1% during charge at any time the battery will explode. The charge current, nominal voltage and cell count set on the charge program must always be correct for the battery to be charged.

Lithium program menu:

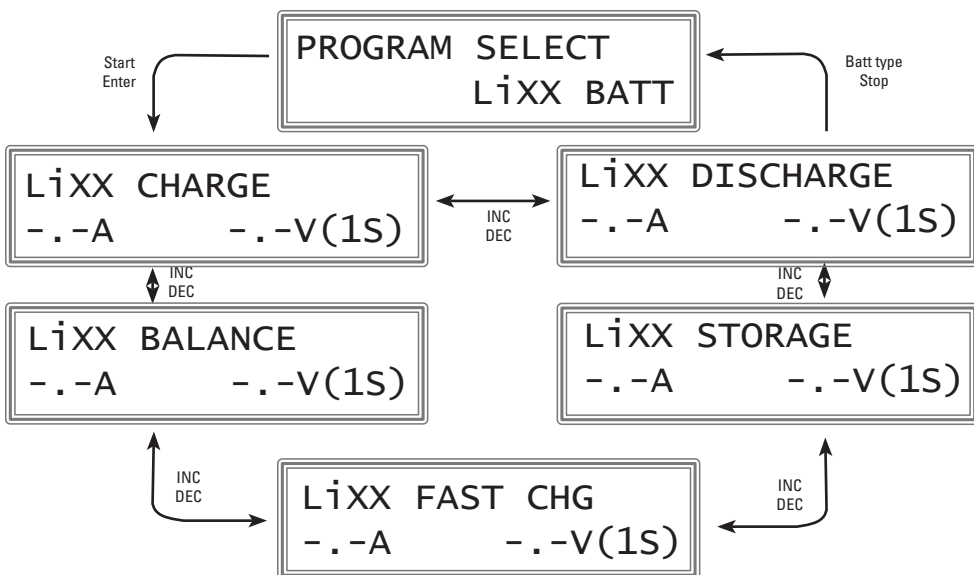

Selecting the correct charge program:

Before using any of the Lithium charge programs you must confirm you have the correct type of lithium battery selected for the one you are about to charge.

To do this enter the "USER SET PROGRAM" option on the main menu. The first option is "V.Type". Choose between LiPo (3.7V), Lilo (3.6V) and LiFe (3.3V) by pressing "Start/Enter" button and then using the "INC" and "DEC" buttons to scroll through these choices. Once you have the correct one selected confirm it by pressing "Start/Enter". (See page 8 for more information on the USER SET PROGRAM options)

How to charge:

1. From the Main Menu scroll to the lithium charge process and choose "PROGRAM SELECT LiXX BATT" from the main menu by pressing the "Start/Enter" button.

The display should look similar to this:

The value on the left of the second line denotes the charge current and the value on the right of the second line denotes the voltage and cell count of the battery pack to be charged.



NOTE: At this stage you need to ensure you have the correct type of battery selected for the type you are about to charge, if you have the wrong type selected you need to exit the charge program immediately and change the setting in the "USER SET PROGRAM" menu.

2. If you need to alter the settings for the charge press the "Start/Enter" button to make it blink then change the value with "DEC" or "INC" button. The value will be stored by pressing "Start/Enter" button.

3. Once the settings are correct press and hold the "Start/Enter" button to begin the charge process. The display will now show similar to the following:

Top Line: S = Number of cells selected by you in the previous screen.
 R = Number of cells detected by the charger.

4. If these values are different press the "Batt type/Stop" button to return to the previous screen to adjust the settings. If both of these values are the same begin charging by pressing the "Start/Enter" button.



5. Once you have started the charge process the following information will display:

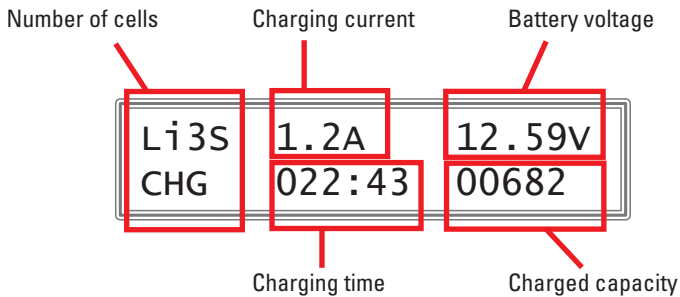

6. The charger will emit a sound to inform you when the charge process is complete. To stop the charge process early press the "Batt type/Stop" button.

LITHIUM BALANCE CHARGE PROGRAM

- *The following program is only suitable for charging and balancing Lithium batteries with a nominal voltage of 3.7V, 3.6V or 3.3V/cell. Do not try to charge any other type of battery using this program.*

This program is for balancing the voltage of LiPo, Lilo or LiFe battery cells while charging. To charge a LiPo, Lilo or LiFe battery using this program the battery needs to have a suitable balance lead.

The BALANCE CHARGE program is different to that of the CHARGE program. In this charge process the voltage of each individual cell is monitored and the charging current fed into each cell is controlled to balance the voltages.

How to charge:

Follow steps 1-6 of the Lithium Charge program.

VIEWING THE VOLTAGE OF INDIVIDUAL CELLS

This charge process allows you to monitor the voltage of individual cells whilst charging.

To use this function press the "INC" button during the charge process.

The display will look similar to this:

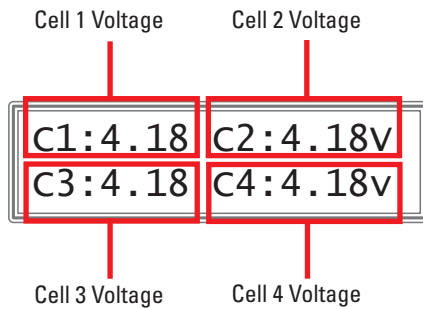

Press "INC" again to view the remaining 5-8 cells.

ERROR MESSAGE DURING BALANCING

If the voltage of one or more cells varies abnormally during the balance charge process the LiPro Quad 6 will immediately terminate the process and the following error will display:



To view the status of individual cells during this error message press the "INC" button.

NOTE: If there is a connection break in the circuit the voltage value may show zero.

LITHIUM FAST CHARGING

Use this program to safely speed up the normal charging process by a small amount. Charge capacity may be slightly reduced at the expense of a shorter charging time.

1. Select this charge process by choosing **LiXX FAST CHG** from the Lithium program menu by pressing the "Start/Enter" button. The display should look similar to this:

LiPo	FAST	CHG
2.0A	11.1V	(3S)

The value on the left of the second line denotes the charge current and the value on the right of the second line denotes the voltage and cell count of the battery pack to be charged.

NOTE: At this stage you need to ensure you have the correct type of battery selected for the type you are about to charge, if you have the wrong type selected you need to exit the charge program immediately and change the setting in the "USER SET PROGRAM" menu.

2. If you need to alter the settings for the charge press the "Start/Enter" button to make it blink then change the value with "DEC" or "INC" button. The value will be stored by pressing "Start/Enter" button.
3. Once the settings are correct press and hold the "Start/Enter" button to begin the charge process. The display will now show similar to the following:

LI3s	2.0A	12.59V
FAS	0.22:43	00682

4. The charger will emit a sound to inform you when the charge process is complete. To stop the charge process early press the "Batt type/Stop" button.

LITHIUM STORAGE CHARGING

Use this program to bring the cells to a set voltage if you plan to store the battery pack for a period of time. The voltages are 3.85 for LiPo, 3.75V for Lilo and 3.3V for LiFe. The charger will charge or discharge the battery to the set voltage for that type of battery depending on the start voltage.

1. Select this charge process by choosing **LiXX STORAGE** from the Lithium program menu by pressing the "Start/Enter" button. The display should look similar to this:



The image shows a rectangular LCD display with a double-line border. The text on the display is arranged in two lines. The first line reads "LiPO STORAGE". The second line reads "2.0A" followed by a wide gap and then "11.1V(3S)".

The value on the left of the second line denotes the charge current and the value on the right of the second line denotes the voltage and cell count of the battery pack to be charged.

NOTE: At this stage you need to ensure you have the correct type of battery selected for the type you are about to charge, if you have the wrong type selected you need to exit the charge program immediately and change the setting in the "USER SET PROGRAM" menu.

2. If you need to alter the settings for the charge press the "Start/Enter" button to make it blink then change the value with "DEC" or "INC" button. The value will be stored by pressing "Start/Enter" button.
3. Once the settings are correct press and hold the "Start/Enter" button to begin the charge process. The display will now show similar to the following:



The image shows a rectangular LCD display with a double-line border. The text on the display is arranged in two lines. The first line reads "LI3s 2.0A 12.59V". The second line reads "STO 0.22:43 00682".

4. The charger will emit a sound to inform you when the charge process is complete. To stop the charge process early press the "Batt type/Stop" button.

LITHIUM DISCHARGING PROGRAM

Use this program to discharge LiPo, Lilo or LiFe batteries.

WARNING: Do not store lithium batteries in a discharged state.

1. Select this charge process by choosing **LiXX DISCHARGE** from the Lithium program menu by pressing the "Start/Enter" button. The display should look similar to this:



LiPo DISCHARGE
2.0A 9.0V(3S)

The value on the left of the second line denotes the discharge current and the value on the right of the second line denotes the voltage and cell count of the battery pack to be charged.

NOTE: At this stage you need to ensure you have the correct type of battery selected for the type you are about to discharge, if you have the wrong type selected you need to exit the charge program immediately and change the setting in the "USER SET PROGRAM" menu.

WARNING: THE CURRENT VALUE ON THE LEFT OF THE SECOND LINE MUST NOT EXCEED 1C. THE FINAL VOLTAGE ON THE RIGHT SHOULD NOT BE UNDER THE VOLTAGE LEVEL RECOMMENDED BY THE BATTERY MANUFACTURER TO AVOID OVER DISCHARGING. IF YOU ARE UNSURE SEEK ADVICE FROM YOUR LOCAL MODEL SHOP.

2. If you need to alter the settings for the discharge press the "Start/Enter" button to make it blink then change the value with "DEC" or "INC" button. The value will be stored by pressing "Start/Enter" button.
3. Once the settings are correct press and hold the "Start/Enter" button to begin the charge process. The display will now show similar to the following:

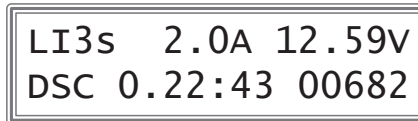

LI3s 2.0A 12.59V
DSC 0.22:43 00682

4. The charger will emit a sound to inform you when the process is complete. To stop the discharge process early press the "Batt type/Stop" button.

NIMH AND NICD CHARGE PROGRAMS

- *These programs are only suitable for charging NiMH (Nickel-Metal-Hydride) or NiCd (Nickel-Cadmium) batteries associated with R/C model applications. Do not try to charge any other type of battery using this program.*

This program simply charges the battery using the current you set, the charge current ranges from 0.1 to 5A.

How to charge:

1. Choosing the right program:

NiMH Batteries: Select "PROGRAM SELECT NiMH BATT" from the main menu then select "NiMH CHARGE" from the NiMH BATT menu by pressing the "Start/Enter" button.

NiCd Batteries: Select "PROGRAM SELECT NiCd BATT" from the main menu then select "NiCd CHARGE" from the NiCd BATT menu by pressing the "Start/Enter" button.

The display should look similar to this:



2. The NiMH and NiCd charge processes can be "Aut" (Automatic) or "Man" (Manual). The selected mode is shown in the top right of the display. To toggle between "Aut" and "Man" Press the "Start/Enter" button to make the current field flash and then press and hold the "INC and "DEC" buttons simultaneously.
3. **Manual:** The current field in the manual setting is *charge current*. If you need to alter the charge current press the "Start/Enter" button to make it blink then change the value with "DEC" or "INC" button. The value will be stored by pressing the "Start/Enter" button.
Automatic: The current field in the automatic setting is the *upper limit of charge current*. You need to set this to avoid over charging the battery and damaging it. If you need to alter the charge current press the "Start/Enter" button to make it blink then change the value with "DEC" or "INC" button. The value will be stored by pressing the "Start/Enter" button.
4. Once the settings are correct press hold the "Start/Enter" button to begin the charge process. The display will now show similar to the following:

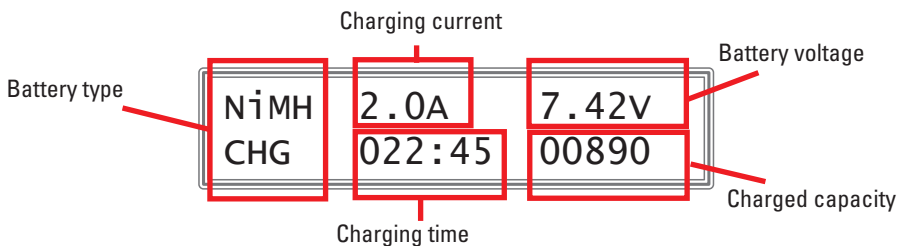

5. The charger will emit a sound to inform you when the charge process is complete. To stop the charge process early press the "Batt type/Stop" button .

NIMH AND NICD DISCHARGE PROGRAMS

- *These programs are only suitable for discharging NiMH (Nickel-Metal-Hydride) or NiCd (Nickel-Cadmium) batteries associated with R/C model applications. Do not try to discharge any other type of battery using this program.*

This program discharges the battery using the current you set, the charge current ranges from 0.1 to 1A.

How to discharge:

1. Choosing the right program:

NiMH Batteries: Select "PROGRAM SELECT NiMH BATT" from the main menu then select "NiMH DISCHARGE" from the NiMH BATT menu by pressing the "INC/DEC" buttons.

NiCd Batteries: Select "PROGRAM SELECT NiCd BATT" from the main menu then select "NiCd DISCHARGE" from the NiCd BATT menu by pressing the "INC/DEC" buttons.

The display should look similar to this:



2. The NiMH and NiCd discharge processes can be "Aut" (Automatic) or manual. To toggle between "Aut" and manual setting Press the "Start/Enter" button twice to make the voltage field flash and then press the "INC and "DEC" buttons to scroll through the voltage AUTO is the first setting.
3. **Manual:** The current field in the manual setting is *discharge current* and the voltage field is *final pack voltage*. If you need to alter the discharge current or voltage press the "Start/Enter" button to make it blink then change the value with "DEC" or "INC" button. The value will be stored by pressing the "Start/Enter" button.

Automatic: The current field in the automatic setting is *upper limit of discharge current* and the final voltage will be determined by the number of cells in the pack (for example a 5 cell NiMH final voltage will be 5V (1V/cell)). You need to set the upper limit of discharge current to avoid over discharging the battery and damaging it. If you need to alter the charge current press the "Start/Enter" button to make it blink then change the value with "DEC" or "INC" button. The value will be stored by pressing the "Start/Enter" button.

4. Once the settings are correct press and hold the "Start/Enter" button to begin the charge process. The display will now show similar to the following:

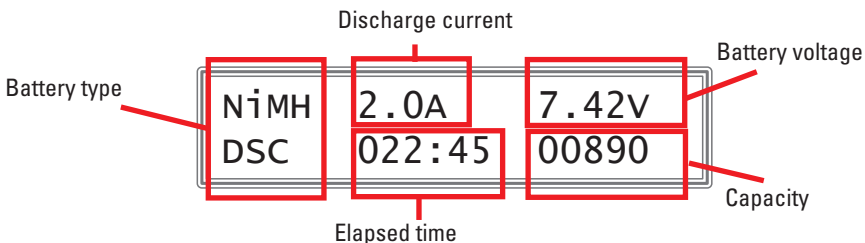

5. The charger will emit a sound to inform you when the charge process is complete. To stop the charge process early press the "Batt type/Stop" button.

NIMH AND NICD CYCLE CHARGE PROGRAMS

- *These programs are only suitable for cycle charging NiMH (Nickel-Metal-Hydride) or NiCd (Nickel-Cadmium) batteries associated with R/C model applications. Do not try to charge any other type of battery using this program.*
- *This program is useful for balancing, refreshing and breaking in new NiMH and NiCd batteries.*
- *There is a period in between charge and discharge cycles to allow the battery to cool down, this can be set in the "USER SET PROGRAM" menu.*

How to charge:

1. Choosing the right program:

NiMH Batteries: Select "PROGRAM SELECT NiMH BATT" from the main menu then select "NiMH CYCLE" from the NiMH BATT menu by pressing the "INC/DEC" button.

NiCd Batteries: Select "PROGRAM SELECT NiCd BATT" from the main menu then select "NiCd CYCLE" from the NiCd BATT menu by pressing the "INC/DEC" button.

The display should look similar to this:



The information on the left of the second line denotes the sequence of the cycle and the value on the right of the second line denotes the number of cycles (1-5).

2. If you need to alter the settings for the process press the "Start/Enter" button to make them blink then change the value with "DEC" or "INC" button. The value will be stored by pressing "Start/Enter" button.
3. Once the settings are correct press and hold the "Start/Enter" button to begin the charge process. The display will now show similar to the following:

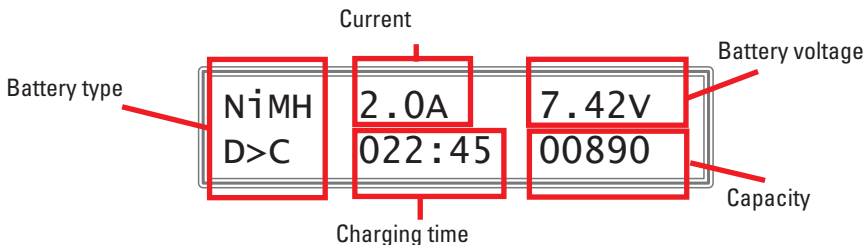

4. To change the discharge current during the process press the "Start/Enter" button once.
5. The charger will emit a sound to inform you when the charge process is complete. To stop the process early press the "Batt type/Stop" button.
6. At the end of the process you can view the charge and discharge capacities of the battery at each cyclic process. By pressing the "INC" or "DEC" buttons the information will be shown in cycle order.

GEL CELL (PB, LEAD ACID) CHARGE PROGRAM

- *The following program is only suitable for charging Gel cell (Pb, Lead-Acid) batteries with nominal voltage from 2V-20V. Do not try to charge any other type of battery using this program.*

Gel cell batteries are completely different to NiMH and NiCd batteries, they can only deliver relatively low current compared to their capacity and similar restrictions apply to the charge process. For this reason the charge current for gel cell batteries should be 1/10 of the capacity. Gel cell batteries must not be charged rapidly, always follow the instructions supplied by the manufacturer of the battery.

How to charge:

1. Select "PROGRAM SELECT Pb BATT" from the main menu then scroll to "Pb CHARGE" using the "INC" or "DEC" buttons and press the "Start/Enter" button to select. The display should look similar to this:



The charge current is displayed in the lower left.

The nominal voltage is displayed in the lower right.

The charge current ranges from 0.1 to 5A. The voltage should match the voltage of the battery to be charged.

2. If you need to alter the charge current or the voltage press the "Start/Enter" button to make it blink then change the value with "DEC" or "INC" button. The value will be stored by pressing the "Start/Enter" button.
3. Once the settings are correct press and hold the "Start/Enter" button to begin the charge process. The display will now show similar to the following:

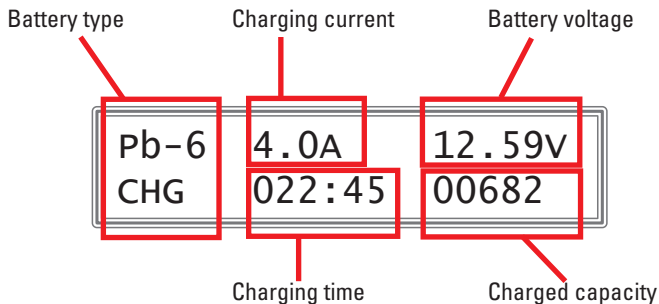

4. The charger will emit a sound to inform you when the charge process is complete. To stop the charge process early press the "Batt type/Stop" button.

GEL CELL (PB, LEAD ACID) DISCHARGE PROGRAM

- *The following program is only suitable for discharging Gel cell (Pb, Lead-Acid) batteries with nominal voltage from 2V-20V. Do not try to discharge any other type of battery using this program.*

How to discharge:

1. Select "PROGRAM SELECT Pb BATT" from the main menu then scroll to "Pb DISCHARGE" using the "INC" or "DEC" buttons and press the "Start/Enter" button to select. The display should look similar to this:



The discharge current is displayed in the lower left.

The final voltage is displayed in the lower right.

The discharge current ranges from 0.1 to 1A. The voltage should match the voltage of the battery to be discharged.

2. If you need to alter the current or the voltage press the "Start/Enter" button to make it blink then change the value with "DEC" or "INC" button. The value will be stored by pressing the "Start/Enter" button.
3. Once the settings are correct press and hold the "Start/Enter" button to begin the discharge process. The display will now show similar to the following:

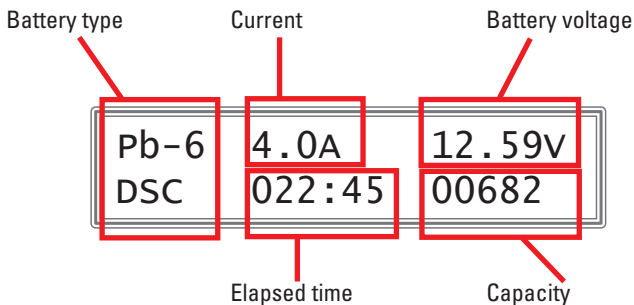

4. To change the discharge current during the process press the "Start/Enter" button once.
5. The charger will emit a sound to inform you when the process is complete. To stop the process early press the "Batt type/Stop" button.

SAVE DATA PROGRAM

The LiPro Quad 6 charger has the capacity to store up to 5 charge programs per charger (a total of 20), useful for storing programs for specific batteries.

These programs can be recalled at any time without having to set up the program again.

Programs can be saved for the following types of battery only:

LiPo, NiMH, NiCd and Gel cell (Pb, lead acid).

The parameters set up in this program do not affect the charge or discharge process, they only represent the specifications of the battery.

Example: NiMH battery SAVE set-up:

PROGRAM SELECT
SAVE DATA

↓ Start
Enter

SAVE [01] NiMH
14.4V 3000mAh

↓ Press and hold "Start/Enter"
for 3 seconds

NiMH CHARGE At*
CUR LIMIT 5.0A

↓ INC
DEC

NiMH DISCHARGE*
4.0A 11.0V

↓ INC
DEC

NiMH CYCLE *
DCHG>CHG 3

↓ Press and hold "Start/Enter"
for 3 seconds

Save...

Select PROGRAM SELECT SAVE DATA from the main menu by pressing the "Start/Enter" button.

Use this screen set up the battery specifications. To alter a value press the "Start/Enter" button and then press "INC" or "DEC". To enter the settings for the program press and hold the "Start/Enter" button.

Set up the charge current for **Manual** mode or the current limit for **Automatic** mode. Toggle between automatic and manual by pressing "Start/Enter" and then the "INC" and "DEC" buttons simultaneously.

Set up the discharge current and final voltage.

Set up the sequence of charge to discharge cycles and the number of cycles.

Press and hold "Start/Enter" to save the program.

Note: For the different batteries these screens will be different but the instructions on how to change values and save the data is the same.

LOAD DATA PROGRAM

This option recalls the programs saved in the "SAVE DATA" screen.

1. Select "PROGRAM SELECT LOAD DATA" from the main menu and press the "Start/Enter" button to select. The display should look similar to this:

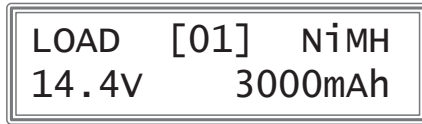

2. Scroll through the saved programs by pressing the "Start/Enter" key and using the "INC" and "DEC" keys.
3. Once you have scrolled to the program required press and hold the "Start/Enter" button.

VIEWING EXTRA CHARGE/DISCHARGE DATA

During the charge/discharge process extra information can be viewed.

VIEWING THE "USER SET PROGRAM" SETTINGS

To view the settings inputted in the "USER SET PROGRAM" settings press the "DEC" button whilst charging or discharging.

MONITORING THE VOLTAGE OF INDIVIDUAL CELLS

To view the voltage of individual cells during the charging/discharging process press the "INC" button.

WARNINGS AND ERROR MESSAGES

This charger incorporates a variety of functions for protection, these monitor the system to verify processes and the state of the electronics. In case of an error the screen will display the cause of error and emit an audible sound.

**REVERSE
POLARITY**

The output is connected to a battery with incorrect polarity

**CONNECTION
BREAK**

This will be displayed if the unit detects a break in the circuit between the battery and output or if the battery is voluntarily disconnected during the charge process.

SHORT ERR

There was a short circuit at OUTPUT. Check the charging leads.

INPUT VOL ERR

The voltage of the input power supply is below the minimum of 12V

**VOL SELECT
ERR**

The voltage of the battery pack to be charged has been selected incorrectly. Verify the voltage of the battery pack.

BREAKDOWN

The charger has malfunctioned for some reason. Seek professional advice.

**BATTERY CHECK
LOW VOLTAGE**

The processor detects that the battery has dropped below the minimum voltage during the charge process. Check the cell count of the battery pack.

**BATTERY CHECK
HIGH VOLTAGE**

The processor detects that the battery has risen above the maximum voltage during the charge process. Check the cell count of the battery pack.

**BATTERY VOL
CEL LOW VOL**

The voltage of one of the cells in a Li-poly battery pack has dropped below the minimum voltage. Check the voltage of the cells individually.

**BATTERY VOL
CEL HIGH VOL**

The voltage of one of the cells in a Lithium battery pack has risen above the maximum voltage. Check the voltage of the cells individually.

**BATTERY VOL
CELL CONNECT**

There is a bad connection at the individual connector. Check the connector and cables carefully.

**CONTROL
FAILURE**

The processor cannot continue to control the charge current for some reason. Seek professional advice.

**European agents: J Perkins Distribution,
Lenham, England**



www.jperkinsdistribution.co.uk